

# AURORALIGHT

## POLARIS INSTALL GUIDE (Wood or Stone)

STW330103

### REQUIRED TOOLS:

3/32 Allen key (included)  
Wire Cutter / Stripper  
2-7/8" or 3" Hole Saw (wood) or core drill (masonry)

### INSTRUCTIONS:

1. To prevent electrical shock, disconnect transformer from electrical supply and make sure power supply is completely off before installation. Fixtures should always be installed by a licensed electrician.
2. Remove the **faceplate** and **fixture housing** from the **PVC Sleeve** by sliding it out.
3. Adjust the aiming of the light by unscrewing the **faceplate** and rotating the **LED module** and/or loosening the **set screw** on the **lamp carriage** to swivel (see figure).
4. Return **faceplate** when done and tighten the **set screw**.
5. If installing a 1/2" conduit adapter into the back of the **PVC Sleeve**, thread them into the **conduit plate**.
6. Measure the physical product to determine the correct hole size and depth for your application (hole will be approximately 2-7/8" to 3" diameter by 6" deep).
7. Pull the **main supply cable** into the **PVC Sleeve**, leave enough slack to make the wire connection outside of it.
8. Secure the **PVC Sleeve** in place with an appropriate epoxy, glue, or other method. The face of the **PVC Sleeve** should be at or slightly below finished surface level (see figure).
9. Connect the **18GA lead wires** to the **main supply cable** using **UL listed wire connectors** suitable for the location.
10. Neatly place the excess wire and connectors in the Sleeve and slide the **faceplate assembly** in until it stops.

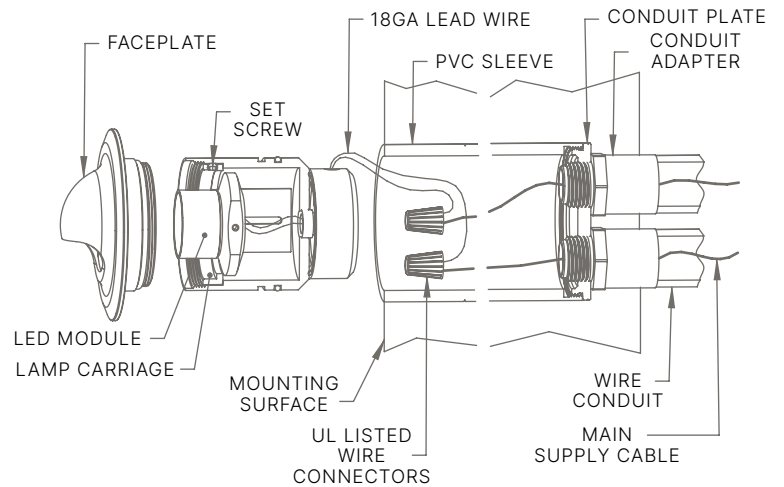

**TIP:** Small gauge cable is vulnerable to damage in the landscape; Protect by routing in close proximity to the luminaire or adjacent to concrete slab or similar structure. Do not over tighten.

P. 760.931.2910

E. techsupport@auroralight.com

O. 2742 Loker Ave. W Carlsbad CA 92010

W. www.auroralight.com

**WARNING:** Luminaire must be installed in accordance with local codes and the National Electrical Code (NEC). Failure to do so may result in serious injury and or damage to the luminaire.

**WARNING:** Risk of electric shock. Install per NEC Code 680.22(B) (6), if listed low voltage luminaires are to be located near a pool, spa or fountain.

# AURORALIGHT

## REQUIRED TOOLS:

3/32 Allen key (included)  
Wire Cutter / Stripper

## POLARIS INSTALL GUIDE (Concrete)

STW330103

### INSTRUCTIONS:

1. To prevent electrical shock, disconnect transformer from electrical supply and make sure power supply is completely off before installation. Fixtures should always be installed by a licensed electrician.
2. Remove the **faceplate** and fixture housing from the **PVC Sleeve** by sliding it out.
3. Adjust the aiming of the light by unscrewing the **faceplate** and rotating the **LED module** and/or loosening the **set screw** on the **lamp carriage** to swivel (see figure).
4. Return **faceplate** when done and tighten the **set screw**.
5. Secure the **PVC Sleeve** to the wire conduit in the desired location. Ensure it is held firmly in place so it doesn't move during the concrete pour (other fastening methods may be required).
6. Pull the **main supply cable** into the **PVC Sleeve**, leave enough slack to make the wire connection outside of it.
7. The face of the **PVC Sleeve** should be at the anticipated finished surface level (see figure).
8. Plug the open top of the **PVC Sleeve** and any unused holes to ensure no wet concrete enters into it during the concrete pour.
9. Pour the concrete and let it cure.
10. Connect the **18GA lead wires** to the **main supply cable** using **UL listed wire connectors** suitable for the location.
11. Neatly place the excess wire and connectors in the Sleeve and slide the **faceplate assembly** in until it stops.

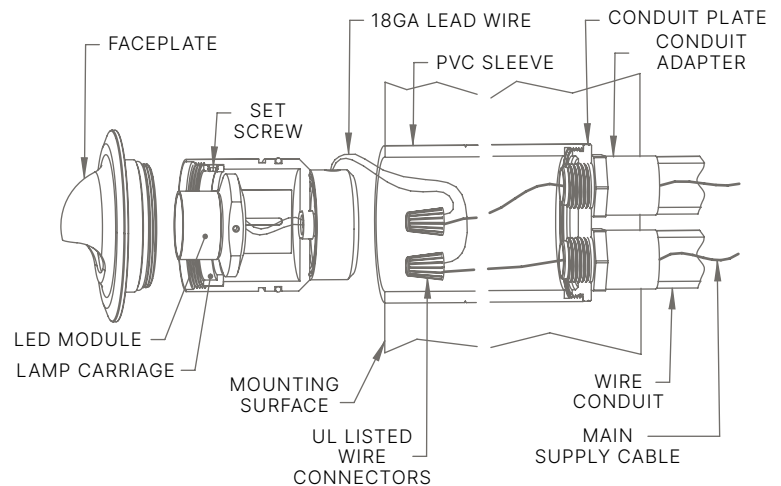

**TIP:** Small gauge cable is vulnerable to damage in the landscape; Protect by routing in close proximity to the luminaire or adjacent to concrete slab or similar structure. Do not over tighten.

P. 760.931.2910

E. techsupport@auroralight.com

O. 2742 Loker Ave. W Carlsbad CA 92010

W. www.auroralight.com

**WARNING:** Luminaire must be installed in accordance with local codes and the National Electrical Code (NEC). Failure to do so may result in serious injury and or damage to the luminaire.

**WARNING:** Risk of electric shock. Install per NEC Code 680.22(B) (6), if listed low voltage luminaires are to be located near a pool, spa or fountain.